

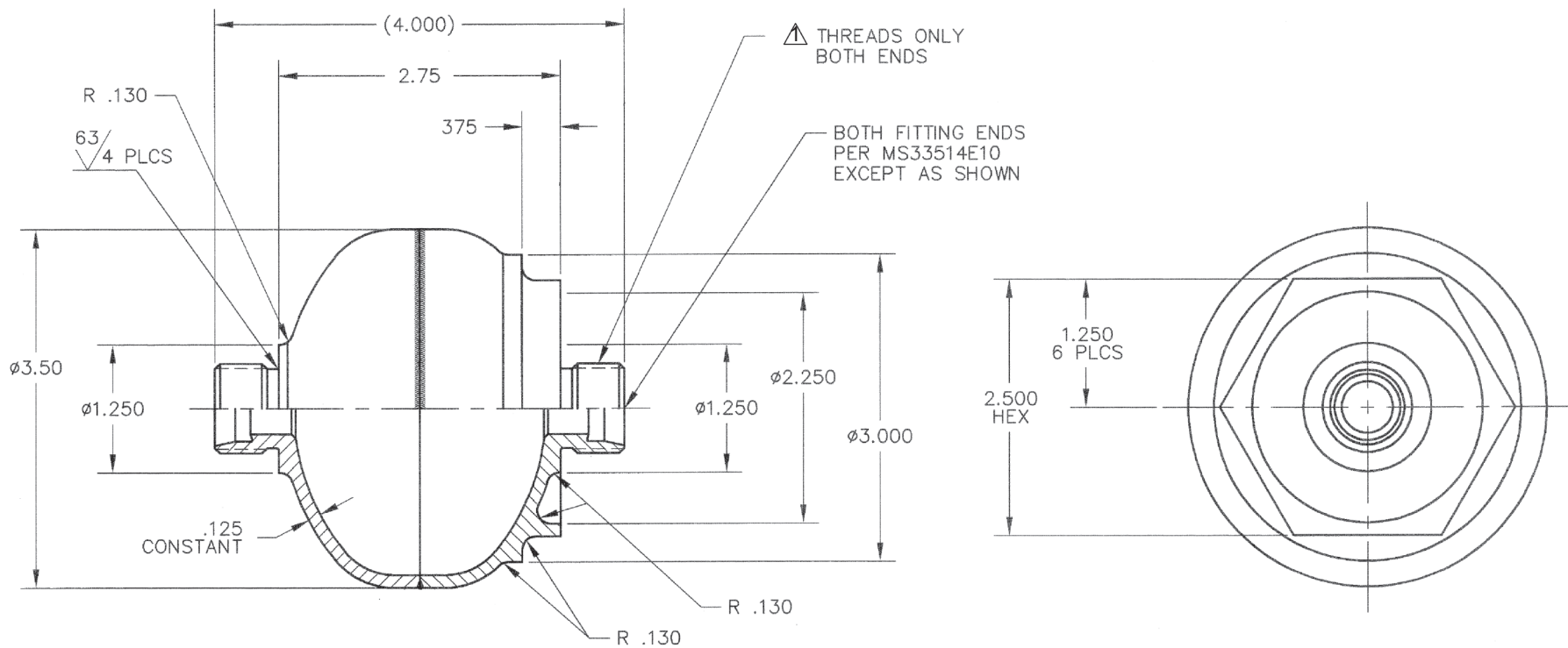

# PART NUMBER: 3A1004-X, ATTENUATOR, HYDRAULIC PUMP



## PERFORMANCE SPECIFICATIONS:

FLUIDS: ANY AIRCRAFT HYDRAULIC FLUID

MATERIAL: BODY 15-5PH CRES

TEMPERATURE RANGE: -65°F TO 225°F

OPERATING PRESSURE: 3000 PSIG

PROOF PRESSURE: 4500 PSIG

 DRY FILM LUBE ON THREADS ONLY



# PART NUMBER: 3A1014-X, PULSATION DAMPER

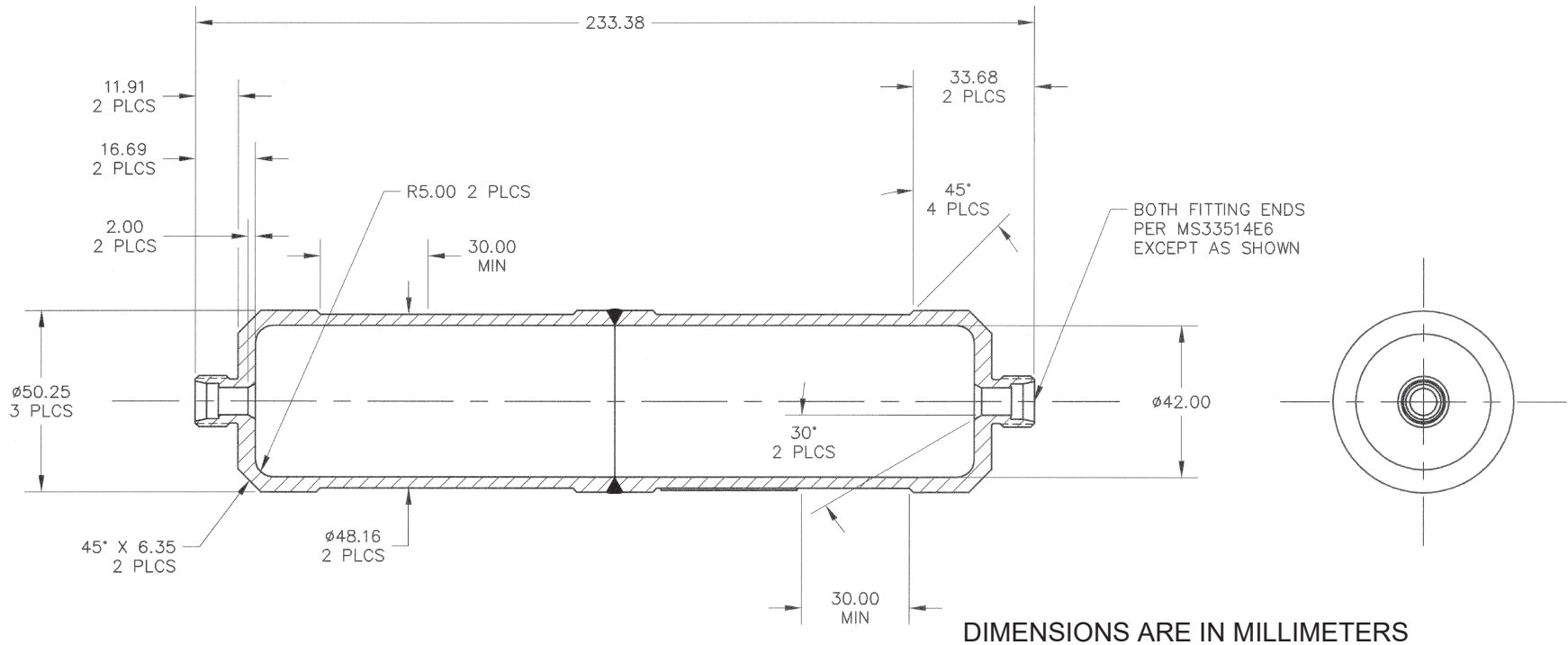

## PERFORMANCE SPECIFICATIONS:

FLUIDS: ANY AIRCRAFT HYDRAULIC FLUID  
MATERIAL: BODY 15-5PH CRES  
TEMPERATURE RANGE: -40°F TO 212°F  
OPERATING PRESSURE: 3000 PSIG  
PROOF PRESSURE: 4500 PSIG  
WEIGHT: 1.94 LBS MAX

CATEGORY 10 OTHER AEROSPACE VALVES: ATTENUATORS



# PART NUMBER: 3A1018-X, ATTENUATOR BALL

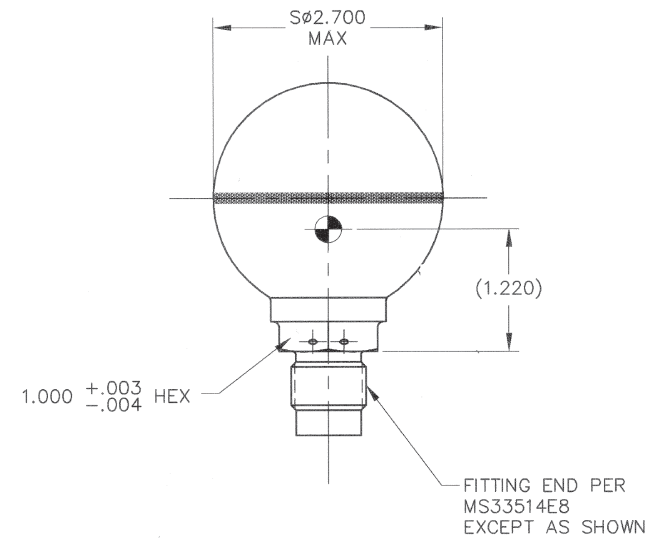
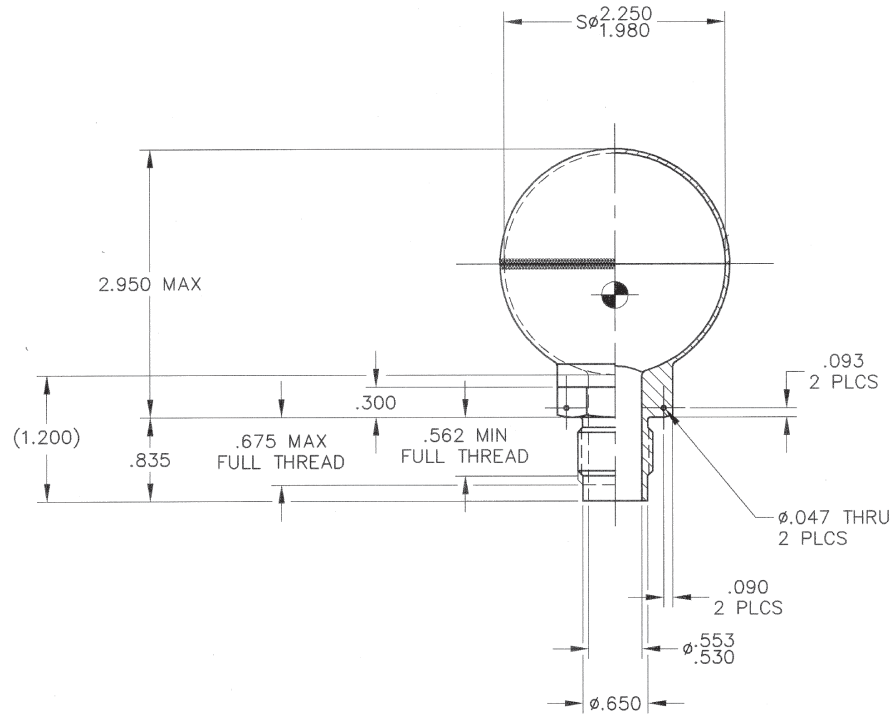

## PERFORMANCE SPECIFICATIONS:

FLUIDS: ANY AIRCRAFT HYDRAULIC FLUID

MATERIAL: BODY 15-5PH CRES

TEMPERATURE RANGE: -65°F TO 275°F

OPERATING PRESSURE: 72 PSIG

PROOF PRESSURE: 150 PSIG

WEIGHT: 0.38 LBS MAX

CATEGORY 10 OTHER AEROSPACE VALVES: ATTENUATORS



# PART NUMBER: 3A1036-X, ATTENUATOR

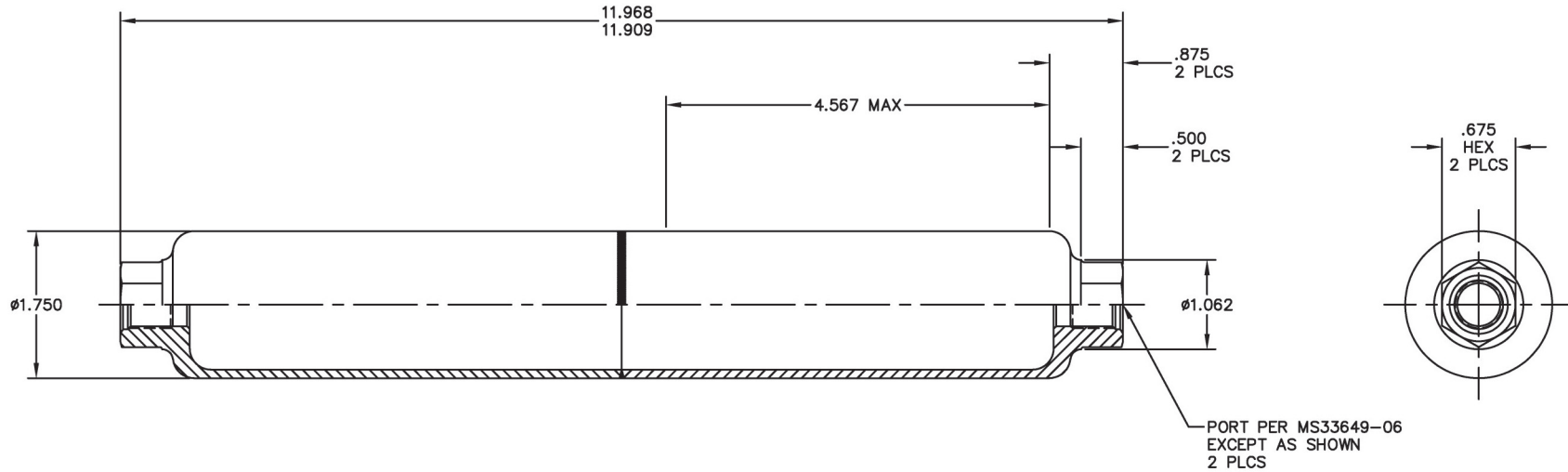

## PERFORMANCE SPECIFICATIONS:

FLUIDS: ANY AIRCRAFT HYDRAULIC FLUID

MATERIAL: BODY 15-5PH CRES

TEMPERATURE RANGE: -65°F TO 275°F

OPERATING PRESSURE: 3000 PSIG

PROOF PRESSURE: 4500 PSIG

FLOW: 6.1 GPM AT 75 PSID MAX PRESSURE DROP WITH 3000 PSI AT 100°F

FIRE RESISTANCE: WITHSTAND A 2000°F FLAME FOR 5 MINUTES

WEIGHT: 2.02 LBS MAX



# PART NUMBER: 3A1046-X, RIPPLE DAMPER

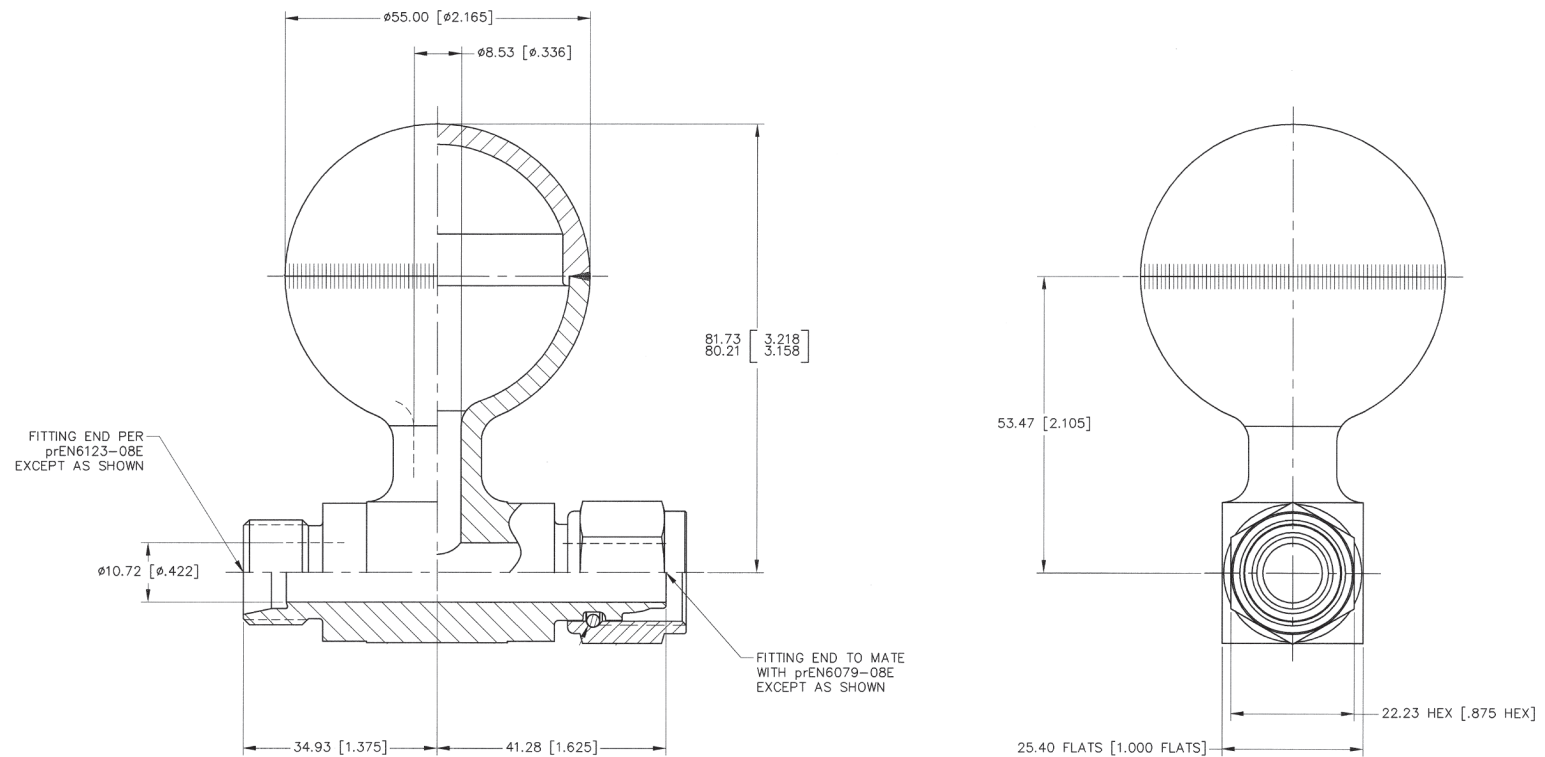

## PERFORMANCE SPECIFICATIONS:

FLUIDS: ANY AIRCRAFT HYDRAULIC FLUID

MATERIAL: BODY 15-5PH CRES

SWIVEL NUT 17-4PH CRES

TEMPERATURE RANGE: NORMAL:  $-40^{\circ}\text{F}$  TO  $201^{\circ}\text{F}$

EXTREME:  $-65^{\circ}\text{F}$  TO  $230^{\circ}\text{F}$

STORAGE:  $-67^{\circ}\text{F}$  TO  $185^{\circ}\text{F}$

SURVIVAL:  $-76^{\circ}\text{F}$  TO  $248^{\circ}\text{F}$

OPERATING PRESSURE: 5000 PSIG

PROOF PRESSURE: 7500 PSIG

FLOW: 13 GPM AT 19.4 PSID MAX

WEIGHT: 1.16 LBS MAX

CATEGORY 10 OTHER AEROSPACE VALVES: ATTENUATORS



# PART NUMBER: 3A1054-X, ATTENUATOR

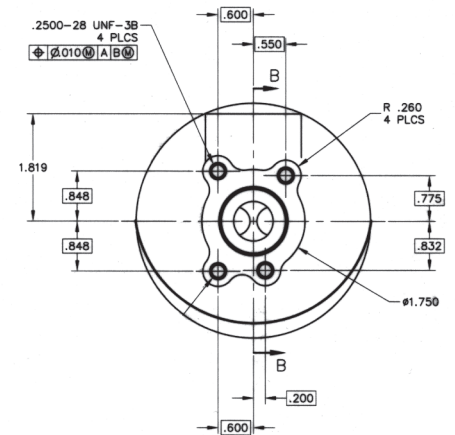
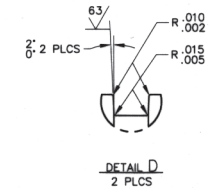
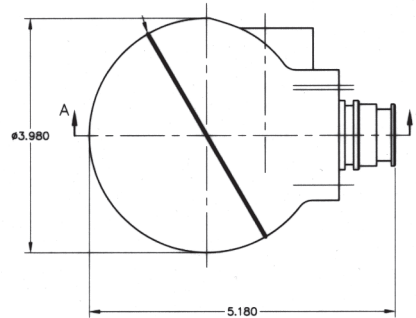
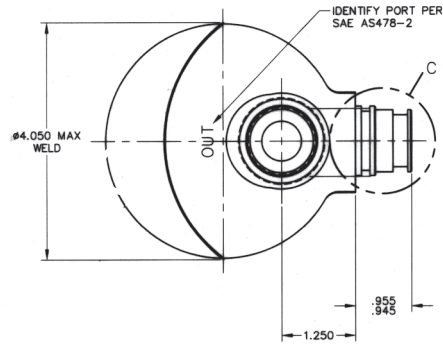
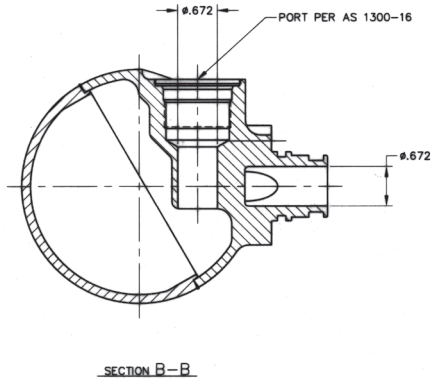
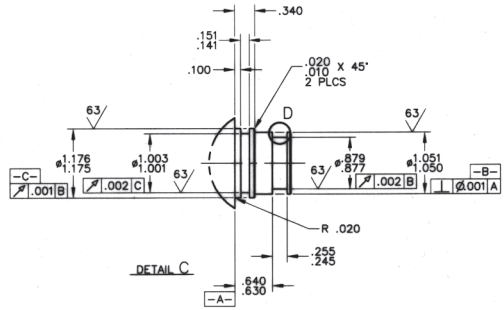

## PERFORMANCE SPECIFICATIONS:

FLUIDS: ANY AIRCRAFT HYDRAULIC FLUID

MATERIAL: BODY 6AL-4V T1

TEMPERATURE RANGE: -65°F TO 300°F

OPERATING PRESSURE: 5050 PSIG

PROOF PRESSURE: 7620 PSIG

WEIGHT: 1.97 LBS MAX